



**JENNCHEM**

PRODUCT CATALOGUE

MISSION STATEMENT

MISSION

To be a responsible employer and leading innovator of sustainably manufactured, and installed, high quality products for mining, industrial and infrastructure markets. Accountable to our stakeholders by creating employee and customer excellence, and positive outcomes for all.



Contents

Mission Statement.....	3
Contacts.....	5
Accreditations.....	6
STANDING SUPPORTS	
Pumpabale Cribs, Surface to Seam Application.....	8
Standard Capacity and High Capacity ACS Props.....	9
400 mm and 600 mm ACS Prop Pans.....	10
SPECIALITY GROUTS AND CEMENTS	
J-Crib - 2 Component Grout Blend.....	12
J-Seal Grout.....	13
J-Fill Grout.....	14
JURR Grout.....	15
J-Plug Grout.....	16
J-Crete (FS) Sprayable Dry Mix Shotcrete.....	17
Bottom-Up 100 MPa Grout.....	18
Top-Down 80 MPa Grout.....	19
Jennchem Mineral Sponge.....	20
STRUCTURAL SUPPORT AND THIN SPRAY LINERS	
TL-40 - Thin Sprayed Liner.....	22
POLYMERIC CHEMICALS	
JennPur Polyurethane Injection Resin.....	24
JennSil - 2 Component Non - Foaming Urea Silicate Resin.....	25
JennThix 2 Component Thixotropic Urea Silicate Resin.....	26
JennFoam - 2 Component High Expansion Phenolic Foaming Resin.....	27
VENTILATION	
AirStop™.....	29

Contacts

Nathan Phie

Operations Manager
E-mail: nphie@jennchem.com.au
Mobile: 0427 209 641

Manufacturing and Administration

Head Office

40-44 Anzac Avenue
Smeaton Grange NSW 2567
Phone: 02 4648 7537

QLD Branch

50-52 Southgate Drive Paget QLD 4740
Phone: 07 4952 8743

NSW Branch

34-38 Anzac Avenue Smeaton Grange
NSW 2567
Phone: 02 4648 7551

Gareth King

Managing Director
E-mail: gking@jennmar.com.au
Mobile: 0418 687 371

Blair Moses

National Safety & Environmental Manager
E-mail: bmoses@jennmar.com.au
Mobile: 0455 612 821

Joel Rodricks

Development Chemist
Email: jrodricks@jennchem.com.au
Mobile: 0427 056 447

Matthew Berry

Commercial Manager
E-mail: mberry@jennmar.com.au
Mobile: 0408 269 658

Luke Cox

Operations Coordinator
Email: lcox@jennchem.com.au
Mobile: 0438 078 482

Jamie Mellish

Maintenance Coordinator
Email: jmellish@jennchem.com.au
Mobile: 0498 445 246



Accreditations

JENNCHEM Australia is certified as compliant with the following standards:



OHS
ISO 45001



Quality
ISO 9001



Environment
ISO 14001



STANDING SUPPORTS



Pumpable Cribs

Pumpable Cribs, Surface to Seam Application

Jennchem is the leader in surface to seam automated grout conveying technology. The Jennchem surface to seam system was originally designed in 2009 for the installation of pumpable cribs in underground coal mines. This system has now evolved into the most reliable, safe and productive unit of its kind boasting install rates of over 8 pumpable cribs per hour.

Features:

- Cost Effective.
- Cylinder shape and small diameter allows for less ventilation restriction than square type standing supports.
- Custom pumpable crib bag sizes can be manufacture to suit any application.
- System designed to pump distances up to 5km.
- Minimises diesel equipment requirements.
- Automated batching process reduces manual labour and in turn reduces the risk of manual labour type injuries.
- All pumpable crib models load tested at 3.6 m height for Quality Assurance.
- Pumpable crib designed with a pillow at the top to ensure complete contact to the roof ensuring even load bearing capability.
- J-Crib Grout coupled with Jennchem’s pumpable crib bag design allows for controlled yielding under ground pressure.
- Rapid gelling characteristics of the J-crib material allows for fast no mess installation.
- High early strength gain of Jennchem’s J-Crib grout provides positive support from the point of install.
- Surface to seam application allows easy installation of standing support for remote areas of the mine where material handling is restricted.



Applications:

Coal Mining

- Tailgate standing supports
- Break off standing supports
- Bleeder road standing supports
- Support for false roofs
- Longwall seal standing support
- Pre-driven recovery road supports

Packaging

- 10 crib bags per pallet



ACS Props and Pans

Standard Capacity and High Capacity ACS Props

Jennchem's ACS Props are designed for applications where instant positive support is required. The ACS prop has been designed with a comprehensive range of load capacities and attachments to suit a variety of load support applications.

Features:

- Light weight
- Small profile provides minimal restriction on ventilation
- Simple, safe and reliable installation
- No mechanical aid required for installation
- Cost effective
- 500 mm height extension
- Instant roof and floor support
- Known, reliable, engineered product



Standard Capacity ACS Props

Part Number	Unextended Height (M)	Extended Height (M)	Typical Load Capacity (Tonnes)
PROPSC1.7	1.2	1.7	50T
PROPSC2.2	1.7	2.2	50T
PROPSC2.7	2.2	2.7	50T
PROPSC3.2	2.7	3.2	50T
PROPSC3.7	3.2	3.7	45T
PROPSC4.2	3.7	4.2	40T

High Capacity ACS Props

Part Number	Unextended Height (M)	Extended Height (M)	Typical Load Capacity (Tonnes)
PROPHC1.7	1.2	1.7	100T
PROPHC2.2	1.7	2.2	100T
PROPHC2.7	2.2	2.7	90T
PROPHC3.2	2.7	3.2	85T
PROPHC3.7	3.2	3.7	80T



ACS Props and Pans

400 mm and 600 mm ACS Prop Pans

Jennchem's ACS Prop Pans are designed exclusively for use with the Jennchem ACS Prop. They are designed to increase the footprint on the roof and floor and also to act as a visual marker for convergence.

Features:

- Specifically designed for use with Jennchem ACS props
- Increases contact with Roof and Floor
- Provides a visual marker for convergence

Part Number	Description
400MMACSPAN	400 mm Diameter ACS Prop Pan
600MMACSPAN	600 mm Diameter ACS Prop Pan

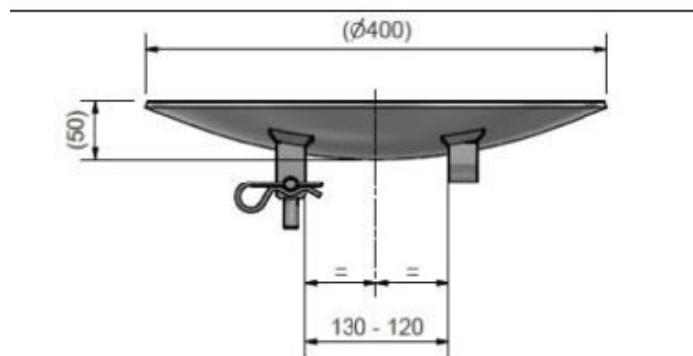
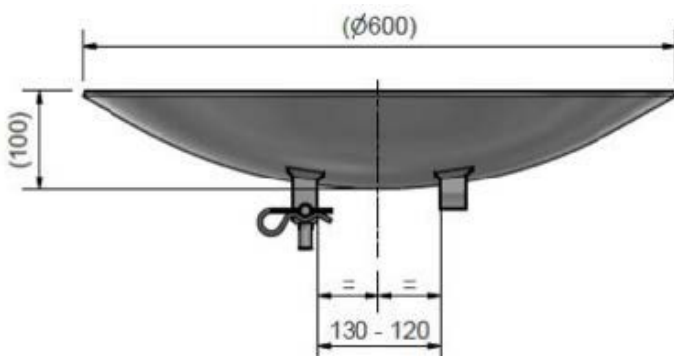

SPECIALITY GROUTS AND CEMENTS

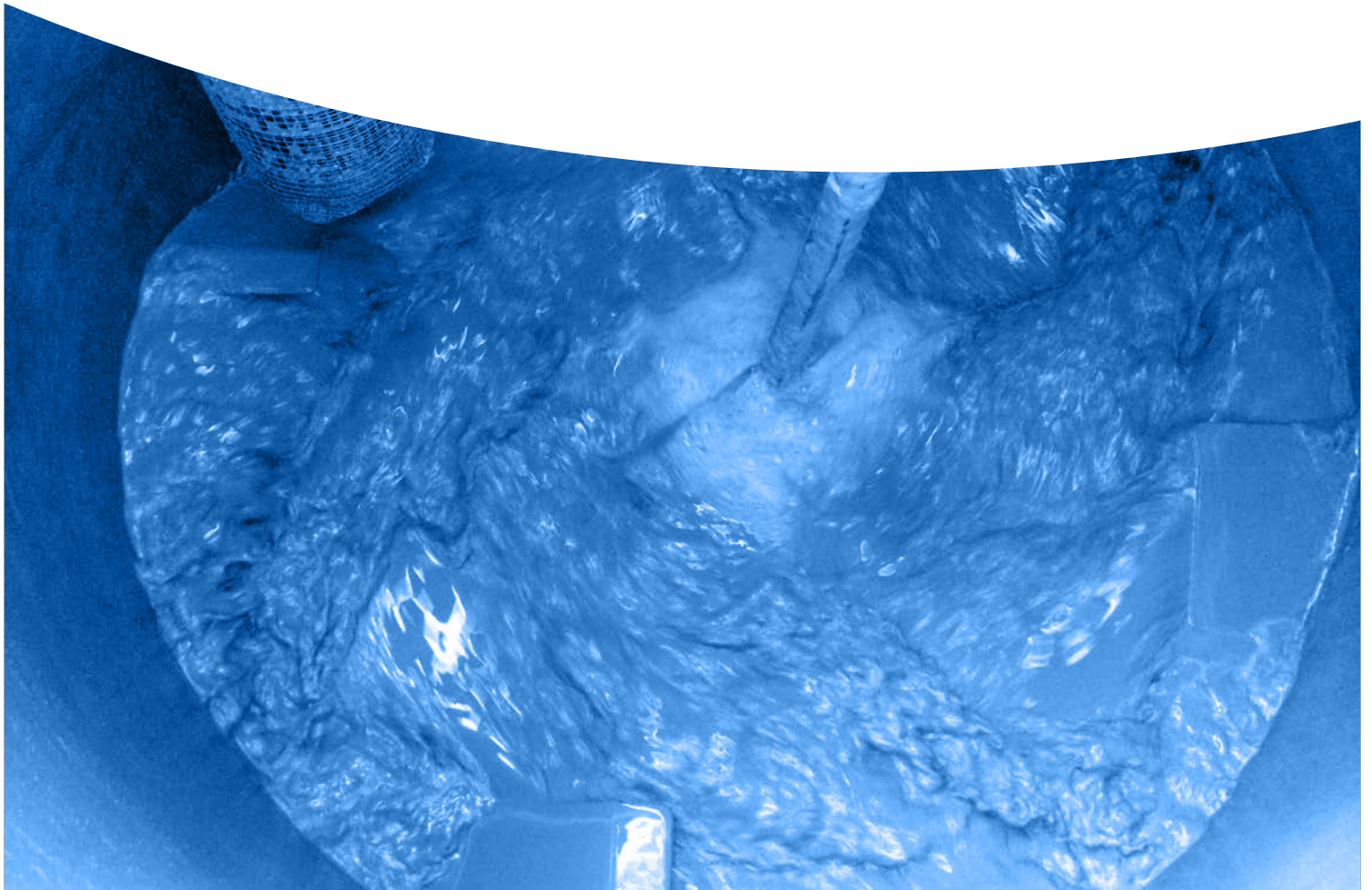

Specialty Grouts and Cements

J-Crib – 2 Component Grout Blend

Jennchem’s J-Crib Grout combines cement, silicate and water to create an extremely fast gelling, high early strength grout purpose built for the filling of Jennchem’s J-Crib pumpable crib bags. J-Crib Grout is batched and delivered utilising Jennchem’s state-of-the-art pumping equipment both from in-seam and surface to in-seam.

Features:

- Dustless application
- Low viscosity
- Great pumpability can be pumped up to 5kms
- Fast gelling
- High early strength
- Non-Flammable
- Non-Toxic
- Surface to in-seam application
- In-seam application

Applications:

- Various water to powder ratios available at the push of a button
- Two component grout, mixed at the point of install
- J-Crib Pumpable Crib fill material
- Void filling
- Back filling
- Pumpable Dam fill material

Packaging:

- Bulk tankers
- 20kg bags
- 1200kg bulk bags

Technical Data — J-Crib - 2 Component Grout Blend

VISCOSITY (Marsh cone) :	28-32 seconds
Gel time :	<40 seconds

J-CRIB STANDARD (MPa) @ W/P 1.2:1

1 day	3 day	7 day	28 day
1.5	3.0	4.3	5.9

J-CRIB HIGH EARLY STRENGTH (MPa) @ W/P 1.2:1

1 day	3 day	7 day	28 day
3.1	6.3	6.6	8.6



Specialty Grouts and Cements

J-Seal Grout

Jennchem's J-SEAL is a pumpable two-component cementitious grout for use in rated plug seals and void filling applications in underground mining. It has a high volume output meaning that significantly less material is required to be mixed with water compared to conventional grouts. J-SEAL is highly pumpable and is mixed at the place of install which allows for greater pumping distance, including remote pumping underground and surface to seam applications.

Features:

- High volume output
- Typically 340 - 440kg produces 1 cubic metre of grout
- Non-shrink, slightly expansive
- Low alkali, safe to handle
- Rapid gelling for ease of placement
- Yields to ground movement
- Two component grout mixed at the point of application
- Great pumpability can be pumped up to 5kms
- High final strength >15MPa
- Extremely durable

Applications:

- Mixing - High shear colloidal mixer
- Pumping - 3 stage progressive cavity pump

Packaging:

- 1 or 1.2 tonne bulk bags
- 20kg plastic bags (56 per pallet)

Technical Data – J-Seal Grout

Water:Power	Fresh Wet Density Mass per m ³ (Kg)	Gel Time (Minutes)	Powder Mass per m ³ (Kg)
1.5:1	1300-1400	3-5	550-650
2:1	1200-1300	3-5	400-440
2.5:1	1160-1260	3-5	340-360

Uniaxial Compressive Strength (MPa)

Water:Power	3 Days	7 Days	28 Days
1.5:1	4	7	15
2:1	2.5	3.3	7.5
2.5:1	1	1.5	4.5

Specialty Grouts and Cements

J-Fill Grout

Jennchem's J-FILL is a pumpable cementitious grout for use in ventilation devices and void filling applications for ground control in underground mining. Jennchem J-Fill has a high volume output which means that significantly less material is required to be mixed with water compared to conventional grouts.

Jennchem's J-FILL is an extremely low viscosity pumpable cementitious grout which gels rapidly to control excessive flow. These properties make J-FILL the perfect choice for consolidation of waste rock fill in the creation of false pillars in hard-rock mines. Also used in ventilation devices and void filling applications for ground control in underground mining. Jennchem J-Fill has a high volume output which means that significantly less material is required to be mixed with water compared to conventional grouts.

Features:

- High volume output, typically 340-440kg produces 1 cubic metre of grout
- Non-shrink
- Low alkali, safe to handle
- Rapid gelling for ease of placement
- Yields to ground movement
- A continuous placer pump is required.

Application:

- A continuous placer pump is required. Consult Jennchem personnel for installation instructions

Packaging:

- 20kg plastic bags (56 per pallet)
- 1 tonne bulk bags



Uniaxial Compressive Strength* (MPa)

Water:Powder	1 Day	7 Days	28 Days
2:1	0.6	3.3	7.5
2.5:1	0.4	1.5	4.5

Water:Power	Fresh Wet Density Kg/m3	Gel Times (minutes)	Kg Powder/m3
2:1	1200-1300	4-8	400-440
2.5:1	1160-1260	6-10	340-360

Specialty Grouts and Cements

JURR Grout (Jennchem Underground Roadway Repair)

Jennchem JURR Grout is a specially formulated fast-setting concrete designed for the mining and tunnelling industries. JURR Grout is designed specifically for demanding applications where quick return to service is required, or where traditional concrete mixing equipment is unavailable or impractical. JURR Grout is formulated to absorb water and gain strength rapidly with no mixing. JURR Grout is ideal for rehabilitating underground roadways and filling mud holes and swillies. JURR Grout is a safer, more permanent solution than temporary bridges or traditional fill methods.

Features:

- Extremely fast setting
- Simple application
- Quick return to service
- Safe to use
- Minimal dust make
- No mixing required
- Packaged in 1 tonne or 20kg bags
- Increases underground development production in wet conditions
- Fit for purpose QDS applicator available

Packaging:

- 20kg bags. (56 per pallet)
- 1 tonne bulk bags

Shelf Life:

- One year when stored in cool dry conditions

Yield:

- 20kg: Approx. 15.4 litres
- 1000kg: Approx. 0.77m³

Set / Cure Time

Foot Traffic	Light Duty Traffic (Drifrunner)	Heavy Duty Traffic (Shuttle car, Jumbo)	Extreme Duty Traffic (Continuous miner)
10 minutes	30 minutes	4 hours	8 hours

Note: Hot materials (and/or water) will accelerate set times and strength gain. Cold materials will slow set times and strength gain. pH and chemistry of water may affect set time and strength gain.



Specialty Grouts and Cements

J-Plug Grout

Jennchem's J-Plug Grout is a pumpable cementitious grout designed for use in void filling applications and plugging of gas drainage holes.

Features:

- High volume output
- Non-shrink.
- Thixotropic
- Rapid setting

Application:

- Use a high shear mixer and potable water
- Water addition-8.5L per 15Kg bag
- Once mixed the product is rapid setting
- Wash all equipment and pumping lines immediately after use

Yield:

- One 15 Kg bag will typically yield 12.5 litres of grout

Packaging:

- 15Kg bags - 72 bags per pallet

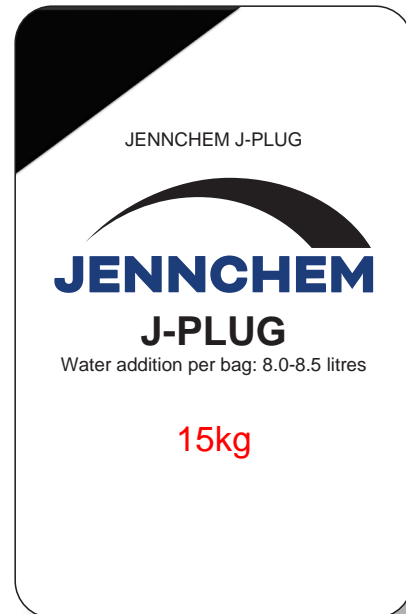

Technical Data – J-PLUG GROUT

Water:powder	Pot Life	Initial set time	Wet Density
0.56 :1	15-20 mins	30-40 mins	1850 Kg/m ³

UNIAXIAL COMPRESSIVE STRENGTH (MPa)

1 Day	7 Days	28 Days
3.5	10	20

Specialty Grouts and Cements

J-Crete (FS) Sprayable Dry Mix Shotcrete

Jennchem's J-Crete is a sprayable dry mix shotcrete for use in the construction of ventilation devices, strata stabilisation and remediation applications for ground control in underground mining.

J-Crete's rapid setting and high early strength characteristics allow for more efficient installation rates and earlier return to service. J-Crete can be applied through any of the industry approved dry shotcreteing equipment.

Features:

- Rapid setting
- High early strength
- Minimum rebound
- Chloride free (non-corrosive to steel)
- Non-Flammable
- Water resistant

Application:

- Rated and non-rated ventilation control devices
- Remediation work
- Strata stabilisation

Application Equipment:

- LOVA Pump
- Piccola Pump

Packaging:

- 20kg bags
- 1000kg, 1200kg bulk bags

	UCS (MPa)	Bond Strength (MPa)	Flexural Strength (MPa)
4 Hours	15	-	-
3 Days	40	21	4.5
7 Days	60	-	6.5
28 Days	75	-	8

Wet density: 2,200 kg/m³



Specialty Grouts and Cements

Bottom-Up 100 MPa Grout

Bottom-Up-100 is a pumpable cementitious grout for use as a bonding agent between a reinforcing member and the borehole wall in ground support systems. The product is packaged in durable water proof 20 kg bags for use in remote and harsh underground mining environments. The product is designed to minimise the risk of hard lumps entering pumping injection systems, which in turn minimises hazardous pressurisation and blockages.

Features:

- High strength 100 MPa cable bolt grout for “bottom-up” grouting
- Ready to use, mix with water and pump
- Excellent pumpability
- Non shrink, unique expansion system compensates for shrinkage
- Typically used with Bowen cables, 15.2mm triple/twin-strand cable bolts and trusses

Packaging:

- Durable water proof 20kg bags for use in remote and harsh underground mining environments
- 56 bags per pallet, 1.2 tonne per pallet



Uniaxial Compressive Strength* (MPa)			
Water Addition	1 Day	7 Days	28 Days**
5 litres/bag	60	100	105
6 litres/bag	55	90	100

*UCS independent test results were obtained using 50 x 50mm cubes

**28 day strength may vary between 85 MPa and 105 MPa depending on water content and testing methods utilised

Water Addition	5 - 6 litres per bag
Estimated Yield	12 - 13 litres per bag

Specialty Grouts and Cements

Top-Down 80 MPa Grout - TD80

TD-80 grout is a pumpable cementitious grout for use as a bonding agent between a reinforcing member and the borehole wall in ground support systems. The product is packaged in durable water resistant 20 kg bags for use in remote and harsh underground mining environments. The product is designed to minimise the risk of hard lumps entering pumping injection systems, which in turn minimises hazardous pressurisation and blockages.

Features:

- High strength 80 Mpa thixotropic cable bolt grout for “top-down” grouting
- Ready to use, requires only the addition of water and mixing
- Non shrink, unique shrinkage compensation formulation
- Excellent pumpability

Application:

- Top-down grouting of groutable cable bolts

Packaging:

- TD80 Grout is packaged in 20kg woven polypropylene bags. Bags are stacked and stretch wrapped onto a wooden pallet for transport. 56 x 20kg bags per pallet



Technical Data

Fresh Wet Density	2000 kg/m ³ (6L water per 20kg bag)
Yield Estimate	13-14 L per bag
Set Time	7 hours
Expansion	1-3%

Uniaxial Compressive Strength* (MPa)

Days	1 Day	7 Days	28 Days
6L/20kg bag	35	78	107
7L/20 kg bag	25	70	96
8L/20 kg bag	16	46	78

*UCS independent test results were obtained using 50x50x50 mm cubes, tested per AS 1478.2

Shelf Life:

- 12 months from manufacture when stored in a cool, dry area, away from direct sunlight and in original packaging.

Storage:

- Store in original packaging in a dry cool area

Specialty Grouts and Cements

Jennchem Mineral Sponge

Mineral Sponge is a calcium aluminate based product used as a binder to agglomerate dust or as a hardening agent to solidify sludge. Mineral Sponge improves waste management as conditions of storage and handling are simplified.

Features:

- High water absorption (up to ten times by weight)
- Rapid setting and hardening
- Non-toxic and ecologically friendly for the environment
- Easy to use

Applications:

- Absorption/solidification of wet areas in the underground environment

Main Constituents:

- Al₂O₃, CaO, SiO₂, Fe₂O₃ + FeO, CaSO₄

Physical Properties:

- Aspect: Powder
- Colour: Grey
- Bulk Density: 1150 kg/m³
- Odour: None
- Inflammable: No
- Explosive: No
- pH in Water: 11,5 - 12,5

Deliveries and Storage Conditions:

Standard Packaging

- 20kg Bags.
- 1 tonne bulk bags

Storage Life

- 6 months maximum, in dry conditions, out of direct sunlight



Specifications

Bulk Density	1150kg/m ³
pH in Water	11.5- 12.5
Absorption Capacity (kg)	10:1

STRUCTURAL SUPPORT AND THIN SPRAY LINERS

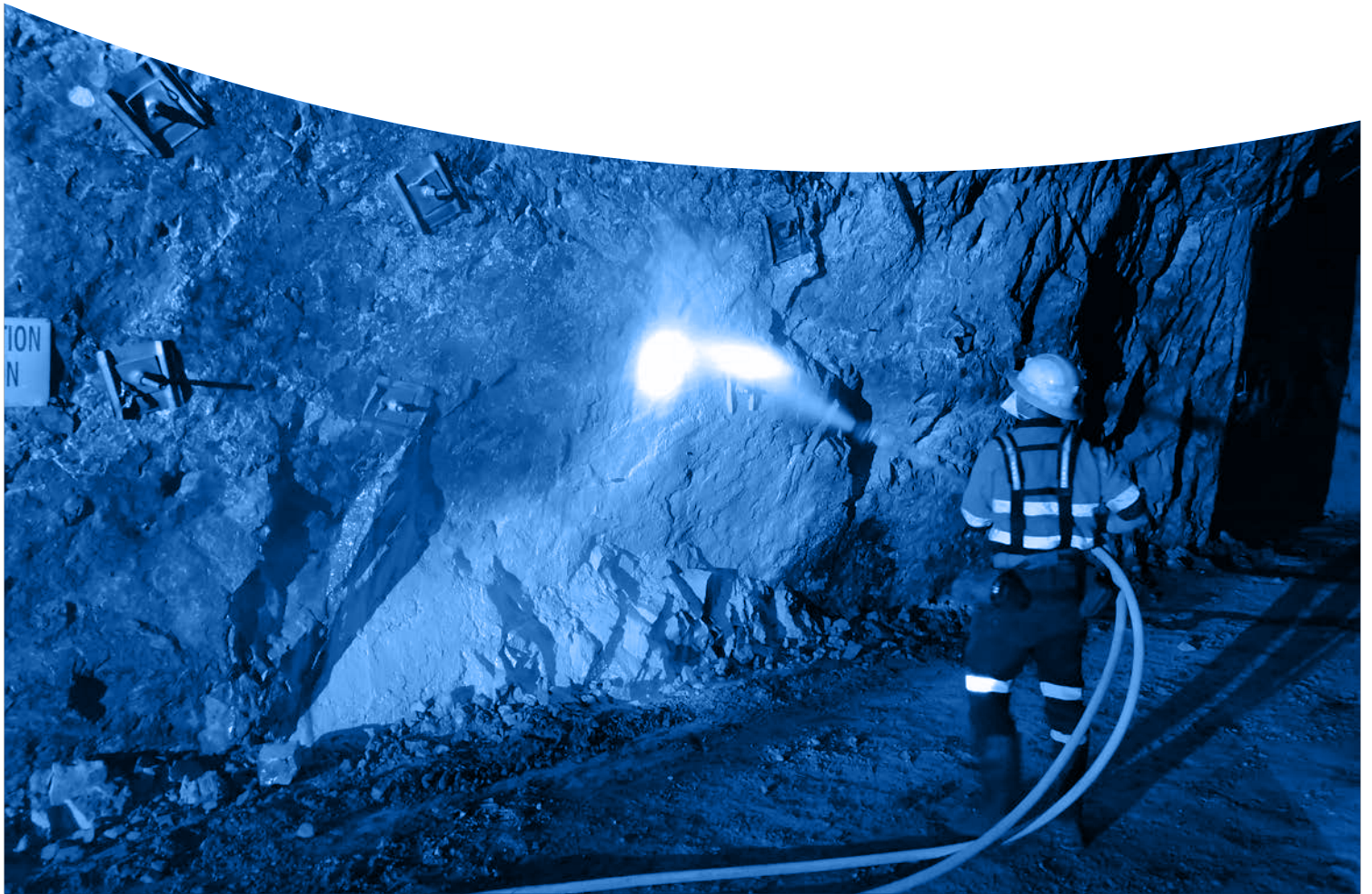

Structural Support and Thin Spray Liners

TL-40 –Thin Sprayed Liner

Two-part spray applied polymer modified membrane for surface sealing and weathering protection of rock and coal substrate.

Features:

- Rapid setting
- High early strength development
- Excellent bond to substrate
- Easily spray applied
- Dustless application
- Can be pumped long distances
- Non toxic
- Low VOC

Packaging:

- Part A - 20kg bags
- Part B - 20L Pales

Application:

- Stabilisation of rock and coal strata
- Flexible surface support
- Temporary or preliminary slope protection
- Non rated ventilation control devices
- Corrosion protection for steel standing support
- Surface support before shotcrete application
- To reduce rock weathering
- Minimise hard rock bursting
- Pillar/Rib Support
- Abutment for low pressure injection

Technical Data – TL-40 - Thin Sprayed Liner

Typical Application Thickness	2 - 12mm
Maximum Thickness	40mm
Density	1900kg/m ³
Bond Strength @ 7 days	
Concrete	>1.7Mpa
Coal	>Substrate Failure
Compressive strength	50Mpa @ 28 days
Tensile Strength @ 7 days	>3.5 Mpa
Flexural Strength	>7Mpa
Elongation at break	60%
Flammability	Self Extinguishing

Mix Design – TL-40 - Thin Sprayed Liner

Part A	4 x 20kg bag
Part B	1 x 20L polymer
Product Volume	42 Litres
Applied Thickness	5mm
Coverage	8.4m ²



POLYMERIC CHEMICALS



JennPur – Polyurethane Injection Resin

JennPur is a two-component Polyurethane injection system, applied at a volume ratio of 1:1 via a high pressure injection system. The two components are pumped separately through high pressure lines, then mixed at the point of injection via a product specific nozzle assembly and static mixer. The low viscosity mix allows for penetration into small cracks and fissures, while the controlled gel time mitigates product wastage.

Features:

- Available in foaming and non-foaming (water sealing) options
- Foams in the presence of water
- Controlled gel time to allow permeation into strata and high early strength gain
- Rapid strength gain for early age load capacity
- Excellent fire resistance

Applications:

- Strata consolidation in both wet and dry strata conditions
- Strata bolt encapsulation
- Water sealing

Packaging:

- 1000L IBCs
- 20L steel drums (32 drums per pallet)

Technical Data – JennPUR

	1:1 (A:B by volume)
Density	CN - Part A : 1160 kg/m ³
	CF - Part A : 1210 kg/m ³
	CN - Part B : 1250 kg/m ³
	CF - Part B : 1250 kg/m ³
Gel time	60-90 Seconds
CF foam start time	45 Seconds
Compressive strength	80 MPa (Unfoamed)
Adhesive strength	>3MPa

JennSil – 2 Component Non – Foaming Urea Silicate Resin

A two component non-foaming urea silicate resin, JennSil provides a semi-flexible, rapid curing ground consolidating product, with the ability to penetrate cracks as small as .25mm wide. JennSil is pumped at a 1:1 ratio by volume and is designed to increase structural integrity in poor and broken ground including underwater applications.

Features:

- Non foaming
- Fast cure times
- High strengths
- Fire resistant
- Penetrates cracks as small as 0.25mm
- Adheres to wet surfaces
- Long or short pumping distances
- Easy installation
- Reacts under water
- Can be used for rock bolt reinforcement
- Assists with corrosion protection

Applications:

- Consolidation of broken ground
- Water stopping in conjunction with other water stopping PUR's.
- Corrosion protection
- Bolt and Cable anchoring
- Underwater applications

Packaging:

- 1000L IBC's
- 20L Drums

Technical Data – JennSil

	Component A	Component B
Colour	Clear, Light Straw	Dark Brown
Density @ 20 C	1.40 - 1.50 g/cm ³	1.15 - 1.25 g/cm ³
Flash Point AS2106.2-2005	>200 C	>200 C
Viscosity	120 - 350 mPas	50 - 300 mPas

Reaction Data	
Gel Time	90 Seconds
Tack free	120-130 Seconds
Exothermic Temperature	115 C

Mechanical Properties	
Compressive Strength	50 Mpa
Flexural Strength	16 MPa
Pull-Out Shear Strength (Strength recorded using 32mm diameter rope thread-bolt to JennSil interface)	9.4 MPa

Cured Sample



Part A



Part B



Polymeric Chemicals

JennThix – 2 Component Thixotropic Urea Silicate Resin

JennThix – Thixotropic 2 component Urea Silicate Resin, is specifically designed to work in harmony with Jennmar rock bolts to provide a single pass bolt installation for underground mining and tunnelling. The fast cure times and ease of installation provide rapid development through poor and wet ground conditions.

Features:

- Non foaming
- Fast cure times
- High strengths
- Fire resistant
- Penetrates cracks >0.25 mm
- Adheres to wet surfaces
- Long or short pumping distances
- Easy installation
- Reacts under water
- Fast anchoring and strength development provides safer underground working conditions
- Assists with corrosion protection

Packaging:

- 25L drums
- 1000L IBC's

Application:

- Bolt and Cable anchoring
- Consolidation of broken ground
- Water stopping in conjunction with other water stopping PUR's.
- Corrosion protection



JENNTIHX

	Component A	Component B
Colour	Clear, Light Straw	Dark Brown
Density @ 20 C	1.40-1.50 g/cm ³	1.15-1.25 g/cm ³
Flash Point AS2106.2-2005	>200 C	>200 C
Viscosity	120-350 mPas	50-300 mPa ^s

Reaction Data A:B = 1:1 By Volume

Start of reaction	Instant after mixing
Tack free	90-100 Seconds
Maximum exothermic temperature	90 C

Mechanical Properties

Compressive Strength	1 Hour	47 Mpa
Flexural Strength	1 Hour	13 MPa
Elastic Modulus	1 Hour	670 MPa



JennFoam – 2 Component High Expansion Phenolic Foaming Resin

Jennchem's JennFoam is a two-component phenolic resin pumped at 4:1 ratio by volume, to form a low strength, fast reacting, high expansion foam ideal for safe and efficient cavity filling applications

Features:

- High expansion x 20
- Fast reaction and cure:
 - Foam Start - instant
 - Foam End 1-2 minutes
 - Surface cure <10 minutes
- Compressive strength 100kpa
- Fire resistant
- Mixed at the point of application to aid in long distance pumping
- Can be used for non-rated ventilation control devices
- Ideal for the safe and efficient filling of cavities

Applications:

- Fall recovery
- Cavity filling
- Consolidation of highly fractured strata
- Non-rated ventilation control devices

Packaging:

- 1000L IBC's

Cured Sample Picture 1



Cured Sample Picture 2



Cut Sample



Technical Data – JennFoam

	Component A	Component B
Colour	Beige-Brown	Dark Red-Brown
Density @ 20 C	1.3 - 1.4 g/cm ³	1.55 g/cm ³
Flash Point AS2106.2-2005	>70°C	>70°C
Viscosity	200 - 400 mPas	<100 mPas
Storage	5°C	20°C
Shelf Life	12 Months	12 Months

Reaction Data

Cured Colour	White-Pink
Gel Time	Instant Foaming
Free Expansion Time	1-2 Minutes
Exothermic Temperature	63°C
Foam Factor-Free Expansion	15-20

VENTILATION

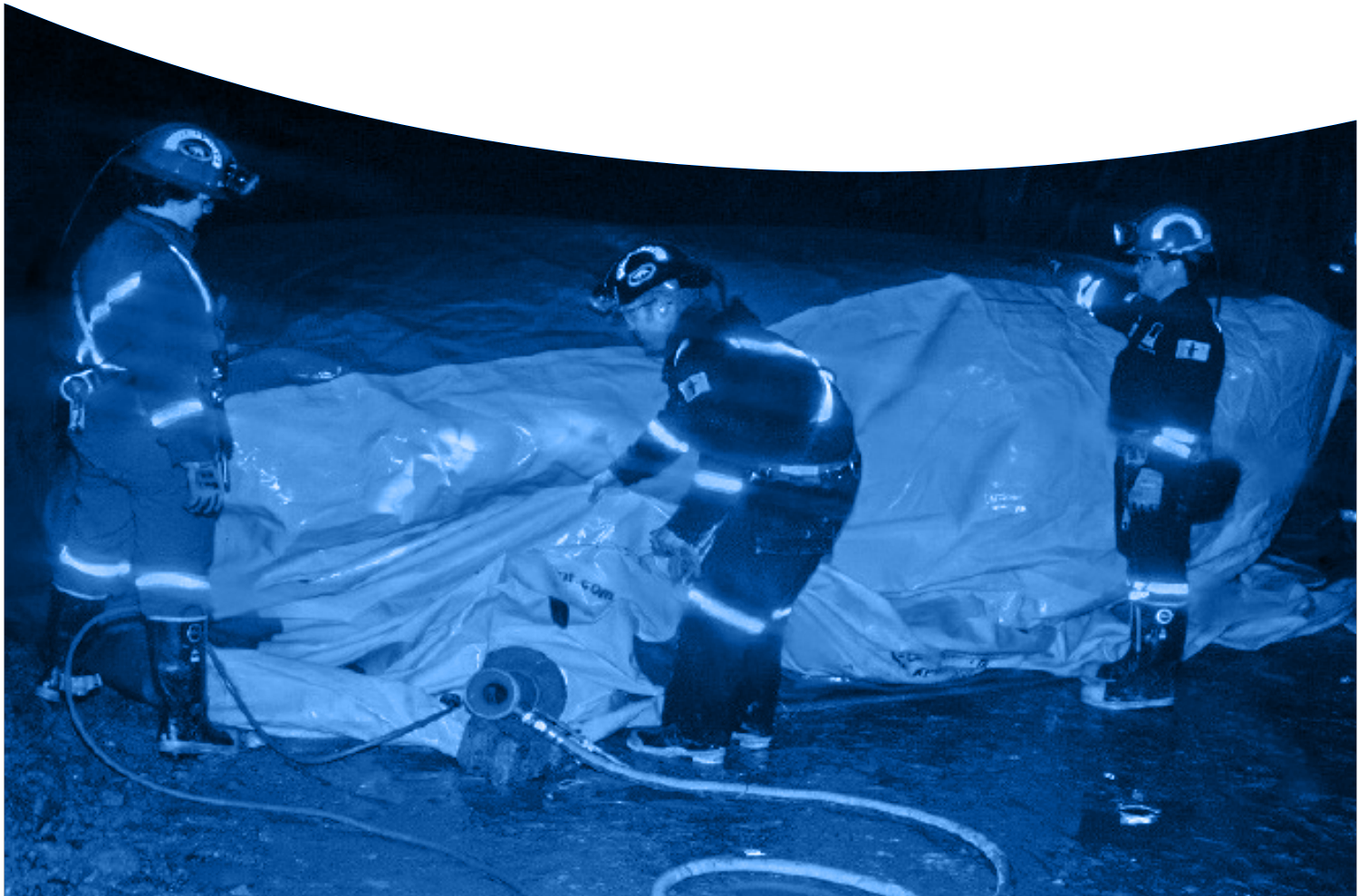

Ventilation

AirStop™

Rapidly Block and Redirect Airflow

The inflatable AirStop™ system is engineered for controlling air-flow in mine and tunnel ventilation. Our patented high-strength inflatable stopping, barrier and seal is manufactured in a range of standard and custom sizes.

Inflatable AirStop™ is a portable and re-usable product that fills horizontal and vertical voids to control air flow, dust, fumes, and smoke. AirStop™ helps maintain a clean breathable air environment by creating a rapid seal. Airstop™ can also be used to redirect mine ventilation during longwall equipment moves or during stopping construction.

Features:

- High-strength inflatable materials
- Standard and custom shapes
- Blocks and redirects airflow
- Control box with air regulator
- Crated for easy transport
- Portable and re-useable
- Rapid deployment and inflation
- Cost effective
- On-site trianing available
- Fire resistant for mining and tunneling
- Safe and efficient
- FRAS material



Registered Patents: # 8727670, 7708070, 2612553, 2612559, 302130, 292812 MSHA Number: 07-BA200001-MSHA



For more information:

E-mail: jpitt@jennmar.com.au

Phone: 0400 494 084

40-44 Anzac Avenue, Smeaton Grange NSW 2567

www.turnstoneindustrial.com

WWW.JENNCHEM.COM.AU

Head Office

40-44 Anzac Avenue, Smeaton Grange NSW 2567
Ph: +61 2 4648 7500

New South Wales Branch

34-38 Anzac Avenue, Smeaton Grange NSW 2567
Ph: +61 2 4648 7551

Queensland Branch

50-52 Southgate Drive, Paget QLD 4740
Ph: +61 7 4952 8743

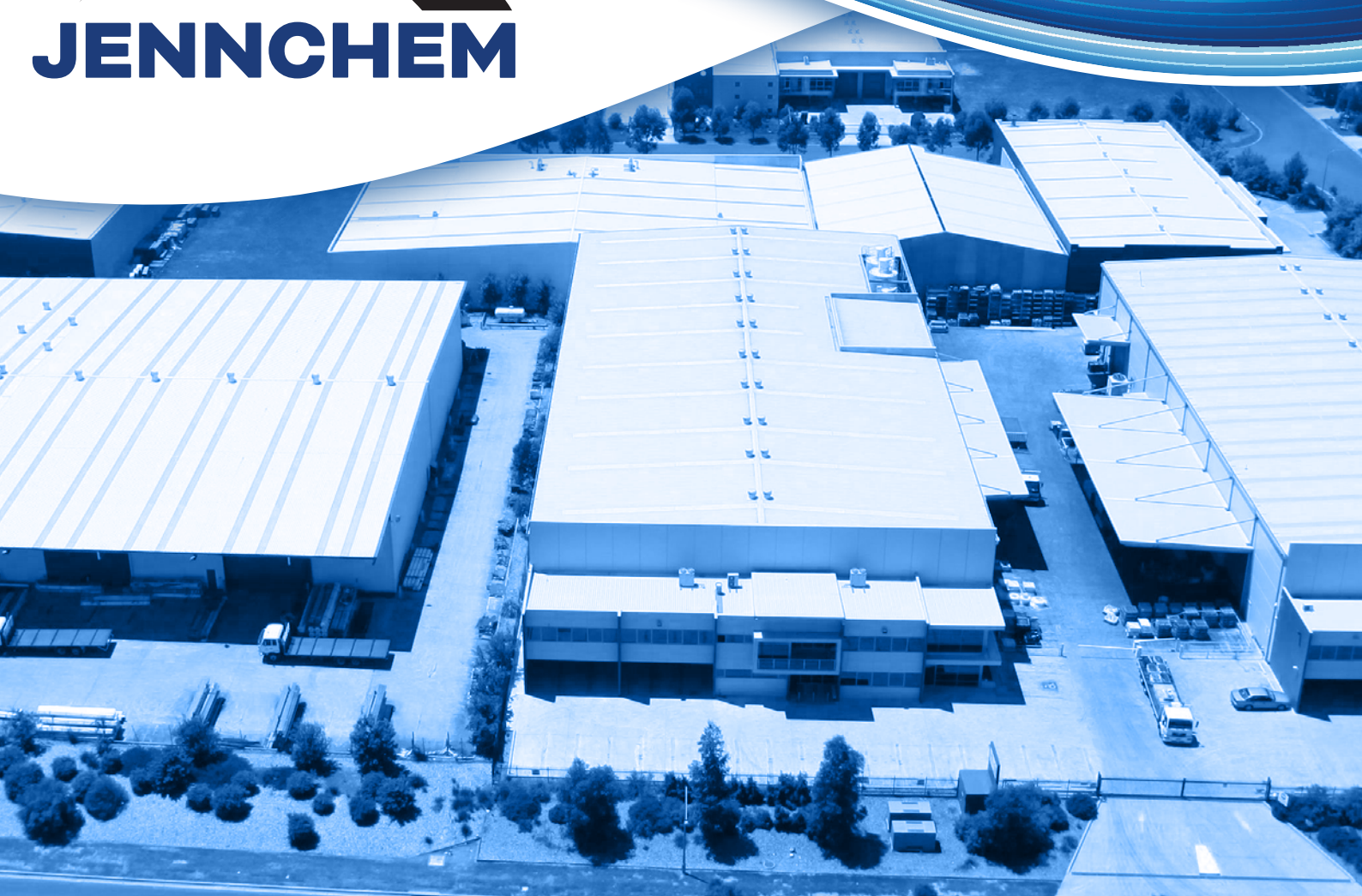

NOTE: Please confirm that you have the latest version of this catalogue by visiting www.jennchem.com.au before using any of the technical specifications contained herein.

072025F